

# PORTACOOOL HURRICANE OWNER'S MANUAL

**PACHR370**



**PORTACOOOL™**

WHEN COMFORT COUNTS™

# QUICK SETUP

1



Remove box and pallet

2



Position cooler on level surface

3



Fill tank or attach water hose

4

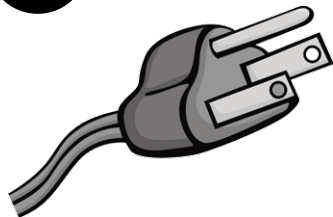

Plug into appropriate outlet

5

For setup, KUUL® evaporative media should appear wet before starting the fan. Check the water gauge to monitor water level in tank. The water adjustment valve on each portable evaporative cooler is set at max flow. However, ensure the knob is turned completely to the right before use. Turn to the left to increase water flow. Less water is required for cooling in more humid environments.

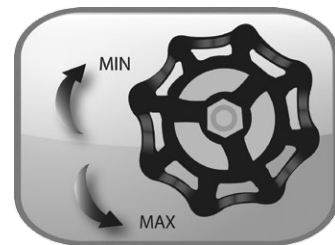

Water adjustment valve

Fill the tank, then turn on the pump switch and the fan

# SAFETY

## OPERATION WARNINGS

- 1) Not for use by children
- 2) Not for use by persons with reduced physical, sensory or mental capabilities
- 3) Not for use by persons who have not reviewed the owner's manual and familiarized themselves with the operation of the product

## SAFE OPERATION

**To reduce the risk of electric shock, fire, or injury:**

- Read the evaporative cooler's instructions, owner's manual and labels before operating.
  - Do not operate evaporative cooler unless all KUUL® evaporative media is securely in place.
  - Operation near open flames or sparks is not recommended.
  - If operating near open flame or sparks, ensure the pump is continuously running in order to saturate and wet KUUL evaporative media.
  - Never wash the evaporative cooler's housing with a garden hose; water may harm the motor or electrical system.
  - Remove the plug from the electrical receptacle by pulling on the plug and not the cord.
  - Do not operate any evaporative cooler with a damaged cord or plug.
  - If the cord or plug become damaged in any way, entire cord should be replaced.
  - Repairs should only be made by qualified individuals and should only be made using authorized Portacool replacement parts.
  - Do not run cord under carpeting. Do not cover cord with throw rugs, runners, or similar coverings. Arrange cord away from traffic area so it will not be tripped over.
- Always unplug the electric cord to the evaporative cooler before performing inspections or repairs.
  - Plug into outlet of appropriate current and voltage capacity.
  - Do not step on or roll over power cord with heavy or sharp objects.
  - The use of extension cords with your evaporative cooler is not recommended. However, if the owner determines that his or her circumstance or intended use requires the use of an extension cord, the following requirements must be met:
    - Extension cord must be 12 gauge or greater;
    - Extension cord must not exceed 50 feet in length; and
    - Extension cord must be properly grounded.
  - Evaporative coolers should not be modified in any way (other than repairs made by qualified individuals with Portacool replacement parts).
  - If the evaporative cooler is damaged or malfunctions, do not continue to operate it. Refer to the warranty, troubleshooting or FAQ sections of this Owner's Manual, call Portacool, LLC Technical Support at 1-888-266-5243, or email [support@portacool.com](mailto:support@portacool.com)

# OVERVIEW



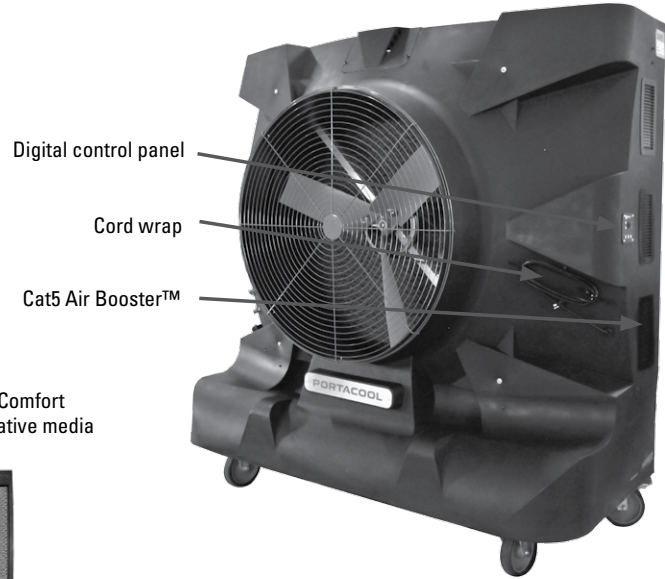
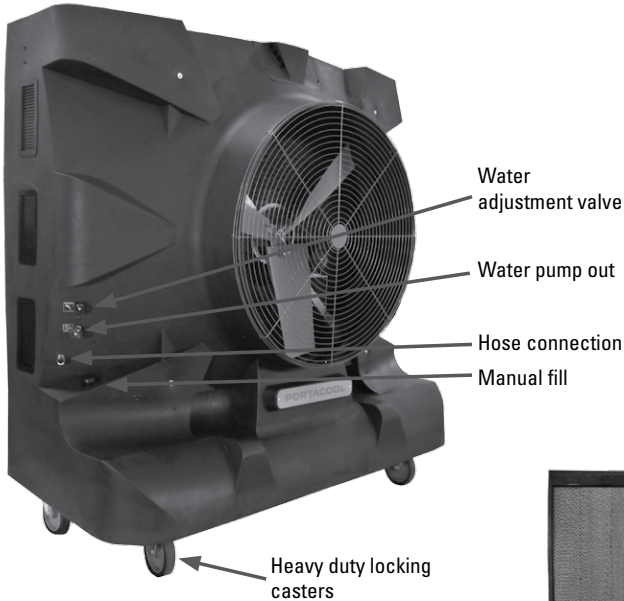

PACHR370

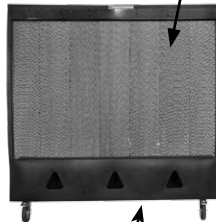

KUUL® Comfort evaporative media



**WARNING:** Consult Owner's Manual. Service by trained personnel recommended.

 <p>Rotating fan blades Can cause serious injury or cut. Keep hands clear. Turn off product before servicing.</p>	 <p>Hazardous voltage inside Disconnect power before servicing. GFCI device required.</p>	 <p>Some components flammable Keep flames and heat away.</p>	 <p>Do not run pump without water in product Can cause damage to components.</p>
---	---	--	--

# DIGITAL CONTROLS

The user interface includes touch sensitive buttons for operation of the Portacool Hurricane™ 370. The user interface also includes status indicator LEDs and a 7-segment display to show the status of the evaporative cooler.

- 1** Power  
The green Power LED is illuminated when the evaporative cooler is plugged in.
- 2** Water level  
The red water level LED is illuminated when the float switch detects a low water level and the pump is not turning on. This LED flashes if the pump is running during a low water occurrence to indicate that more water needs to be added in order to continue running the pump.
- 3** Timer  
The controller features five pre-programmed modes which control the fan / pump sequence for a pre-defined period. Each touch of the program button cycles through the five modes: 1HR, 2HR, 4HR, 8HR, and TIMER OFF. During the program run, the user can adjust the maximum fan speed with the up/down buttons. When the program is active, the Timer LED will be on and, for five seconds, the user will be shown which program (1H, 2H, 4H, or 8H) is active.
- 4** Pump  
Press the pump button once to power on and again to power off. The green Pump LED is illuminated when the pump is enabled. The LED flashes slowly if continuously held and the timer is disabled.
- 5** Fan  
When the fan is off, touch the fan button once to turn the fan on in full speed. When the fan is on, touch of the Fan button again to turn the fan off. The green Fan LED is illuminated when the fan is active. The LED flashes slowly if continuously held and the timer is disabled.
- 6** Speeds  
The buttons control the air velocity of the cooler. Beginning with "Lo", or 30% air flow, then 50%, then up to "Hi" or 100% airflow and increasing in five percent increments.
- 7** Two digits display the cooler's temperature, fan speed, and timer program. If the cooler does not have a temperature sensor connected, the display will constantly show fan speed. If the cooler does feature a temperature sensor, then the temperature is displayed unless: a fan speed change is being called upon either by means of the up/down button or by the timer's program. When a fan speed change is requested, the fan speed will be displayed for five seconds before returning to the cooler temperature.

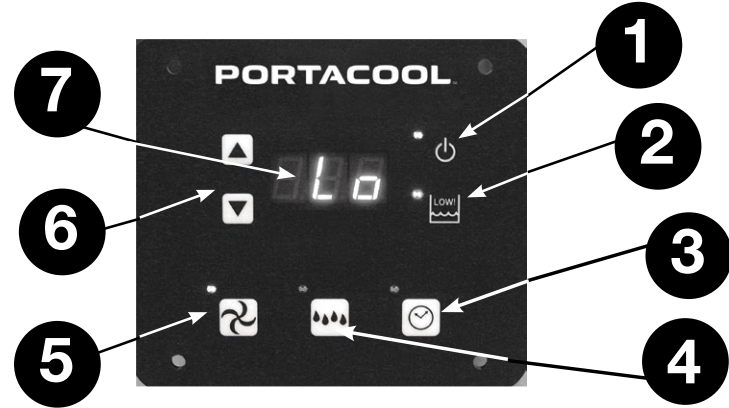

## LOCK OUT FEATURE

If the operator would like to lock settings so that they can't be adjusted, simply press the "up" arrow and the fan button simultaneously to lock the controls. To unlock, press the "down" button and the fan icon. When enabled, "L-E", or "Lock Enabled", will be displayed in the LED.

## FAHRENHEIT VS CELSIUS

If the operator would like to change the temperature setting from Fahrenheit to Celsius, press the fan, motor and timer buttons simultaneously. To switch from Celsius to Fahrenheit, simply repeat the process.

# START UP

## PLACEMENT

- 1) Make sure there is a clear, unobstructed path in front of the evaporative cooler to provide maximum airflow.
- 2) If the evaporative cooler is positioned on a raised platform, ensure the platform is stable, well constructed and will not allow the evaporative cooler to tip over. Ensure it allows for the full weight of the evaporative cooler, including a tank full of water. The evaporative cooler must be level and in the upright position and the casters should be locked to prevent movement.
- 3) If placed near a wall or other obstruction, position the evaporative cooler a minimum of 3 feet (0.9 meters) from the wall or obstruction with the KUUL® evaporative media facing the wall. This allows the unrestricted flow of warm air to the KUUL evaporative media. When using multiple evaporative coolers in close proximity, be sure to aim each evaporative cooler so the air flows complement each other to achieve maximum cooling capacity.

## STARTING THE PUMP AND ADJUSTING THE WATER FLOW

Once the tank is full of water, pressing the "PUMP" button on the digital control panel will turn on the pump. When initially turning on the pump, the water level in the tank will drop suddenly and restart the flow of supply water. This is a normal condition, as the KUUL evaporative media requires a large amount of water for proper wetting.

New evaporative media will require an initial 'breaking-in' period. This period is required for the KUUL evaporative media to begin readily absorbing water. It may require up to a week to achieve maximum efficiency.

It is important to ensure that the water flow to the media is properly adjusted to lowest position when first starting the water flow in the evaporative cooler. Increasing the flow using the water adjustment valve (see Quick Setup in this manual) makes this adjustment. Proper water adjustment should leave the evaporative media saturated with water, but not flooded. Evaporative media should appear wet. When properly adjusted, some dry streaks will appear at the interface of the KUUL evaporative media.

When turning the evaporative cooler off at the end of the day or week, the pump should be turned off about 15 minutes before the fan to allow the KUUL evaporative media to dry.

## STARTING THE PORTACOOOL EVAPORATIVE COOLER

Start the fan by pressing POWER on the digital control panel, then adjust to desired speed. Before starting, make sure casters are in locked position.

ORDER PARTS  
**ONLINE**  
portacoolparts.com

# MAINTENANCE

While the rugged, corrosion-resistant construction ensures low maintenance will be required, keeping your evaporative cooler clean will ensure it stays in peak operating condition.

## **DAILY MAINTENANCE**

The pump should be turned off approximately 15 minutes before the fan is turned off, which allows the KUUL® evaporative media to dry out. Ensuring your KUUL evaporative media is dry at the end of the day not only extends its life, it also helps control the growth of mildew, mold, bacteria and other odor-causing elements.

## **WEEKLY MAINTENANCE**

Your Portacool portable evaporative cooler should be shut down and the tank should be drained once a week. Closing the water adjustment valve and removing the drain plug will accomplish this. Once the tank is drained and the power disconnected, the KUUL evaporative media may be removed to allow cleaning of the tank, where dust may collect over time. Replace KUUL evaporative media in correct airflow direction, referring to the label on the KUUL evaporative media.

## **STORAGE**

- 1) Drain all water from the tank and wipe the tank clean, ensuring the KUUL evaporative media and tank are dry.
- 2) Roll up the power cord and secure it to ensure it will not be rolled over, tripped over or caught in equipment.
- 3) Cover the evaporative cooler completely to prevent dust build-up and store in a dry area. This also helps to prevent damage to the KUUL evaporative media. Optional protective covers are available from your distributor or at [www.portacoolparts.com](http://www.portacoolparts.com).

**ORDER PARTS  
ONLINE**  
portacoolparts.com

# TROUBLESHOOT

Turn off all power to your evaporative cooler before attempting to troubleshoot any of the following symptoms. For problems not listed, please contact customer service.

<b>SYMPTOM</b>	<b>POSSIBLE CAUSES</b>	<b>REMEDY</b>
Evaporative cooler fails to start or deliver air	<ol style="list-style-type: none"> <li>1. No electricity to the evaporative cooler               <ol style="list-style-type: none"> <li>A. Circuit breaker tripped</li> <li>B. Cord(s) unplugged or damaged</li> </ol> </li> <li>2. Motor overheated and/or frozen</li> </ol>	<ol style="list-style-type: none"> <li>1. Check power               <ol style="list-style-type: none"> <li>A. Reset breaker*</li> <li>B. Plug in cord(s) or replace if damaged</li> </ol> </li> <li>2. Replace motor</li> </ol> <p><small>* If condition persists, call electrician</small></p>
Evaporative cooler starts, but air delivery is inadequate	<ol style="list-style-type: none"> <li>1. Insufficient air exhaust</li> <li>2. Insufficient water–KUUL® evaporative media not wet               <ol style="list-style-type: none"> <li>A. KUUL evaporative media plugged</li> <li>B. Dry streaks on KUUL evaporative media</li> <li>C. Large dry spots on KUUL evaporative media</li> <li>D. Pump not working</li> <li>E. Loose water connections</li> </ol> </li> </ol>	<ol style="list-style-type: none"> <li>1. Open windows or doors</li> <li>2. Check water distribution system               <ol style="list-style-type: none"> <li>A. Clean or replace evaporative media</li> <li>B. Check water level</li> <li>C. Make sure evap cooler is level, clean spray bar</li> <li>D. Clean or replace pump</li> <li>E. Check for leaks and correct</li> </ol> </li> </ol>
Knocking, shaking, or rattling sounds	<ol style="list-style-type: none"> <li>1. Loose parts</li> <li>2. Fan blade rubbing shroud</li> </ol>	<ol style="list-style-type: none"> <li>1. Check and tighten where needed</li> <li>2. Inspect and adjust, or replace fan blade</li> </ol>



# TROUBLESHOOT

## SYMPTOM

Musty or unpleasant odor

## POSSIBLE CAUSES

1. Stale or stagnant water in tank
2. KUUL® evaporative media is mildewed or clogged

## REMEDY

1. Drain, flush and clean tank
2. Replace KUUL evaporative media

Water droplets in the air stream

1. Too much water delivered to KUUL evaporative media
2. Leaking hose

1. Make sure KUUL evaporative media is properly positioned in the frames and evaporative cooler is level
2. Tighten connection or replace hose

ORDER PARTS  
**ONLINE**  
portacoolparts.com

# WARRANTY

## **TECHNICAL SUPPORT**

Technical support and service is available directly from your distributor or call Portacool, LLC Technical Support Hot Line at 888-266-5243 for the distributor nearest you. You may also contact the Support Hot Line for consultation on troubleshooting and parts replacement.

Please have serial number and model number of cooler available.

## **WARRANTY AND REPLACEMENT PARTS**

### **PORTACOOOL™ EVAPORATIVE COOLER LIMITED WARRANTY**

For five (5) years from date of purchase, Portacool, LLC (hereafter "Portacool") warrants any original component part or parts of its Portacool™ portable evaporative coolers (the "Equipment") that are found, upon examination by factory-authorized personnel, to be defective in material or workmanship.

Notwithstanding anything herein to the contrary, Portacool warrants its Hurricane 370 housings for the full lifetime of the product to the extent they are found, upon examination by factory-authorized personnel, to be defective in material or workmanship. The Lifetime Warranty on product housings is void if the housing is found upon examination by Portacool to have been misused, abused or otherwise tampered with by unqualified personnel. The Lifetime Warranty on product housings does not cover ordinary wear and tear and is non-transferrable.

If the Equipment and/or its original component parts, including product housings, develop a defect covered by this limited warranty within the applicable time periods described above, the same may be repaired or replaced at the option of Portacool.

All transportation charges for shipment of the Equipment and/or its component parts that are submitted for replacement or repair under this warranty must be borne by the purchaser.

This warranty is void if: i) the Equipment and/or its component parts are found to have been misused, abused, repaired by or tampered with by unqualified personnel; ii) any of the product's component parts have been replaced with parts that were not authorized Portacool replacement parts; iii) the product has been modified in any way (other than repairs made by qualified individuals with Portacool replacement parts); iv) the product has not been appropriately registered by its original purchaser; or v) the customer cannot show proof of purchase as the product's original owner.

## **PORTACOOOL LIMITATION OF LIABILITY**

**IN THE CASE OF A BREACH OF ANY IMPLIED OR WRITTEN WARRANTY RELATING TO THE EQUIPMENT AND/OR ITS COMPONENT PARTS, PORTACOOOL SHALL NOT BE LIABLE FOR ANY INCIDENTAL OR CONSEQUENTIAL DAMAGES, AND THE LIMITS OF LIABILITY AGAINST PORTACOOOL FOR ANY SUCH BREACH SHALL NOT EXCEED THE COST OF REPLACEMENT OR REPAIR OF THE EQUIPMENT.**

# PORTACOOOL PROTECT

Portacool, LLC is proud to provide world-class service and support. Portacool Protect™ brings together our commitment to service and support in the form of best-in-class warranties, service programs, technical support and live customer service to provide our customers with an ownership experience that is second to none.

Each of the following components are included with your Portacool Hurricane™ series product:



Year warranty  
on Hurricane series  
motor and electrical  
components



Lifetime warranty  
on all molded  
 housings



Live, US-based  
Customer  
Service

For complete warranty information and limitations, please see [Warranty page](#). Beyond these aspects of Portacool Protect™, we ask that you not hesitate to contact us with any additional questions or comments you might have. For more than 25 years, we have built our business on service and support. We look forward to speaking with you.

# FAQ

## **Q. What assembly is required?**

A. None. Your Portacool portable evaporative cooler is ready to use right out of the box.

## **Q. How do I prepare my Portacool portable evaporative cooler for storage?**

A. Drain the evaporative cooler, wipe out the tank to ensure it is dry and clean, dry out the KUUL® evaporative media, cover the evaporative cooler, and store in a dry place.

## **Q. I ran my evaporative cooler for the first time and there is an unpleasant odor!**

A. The KUUL evaporative media, located in the back of your Portacool portable evaporative cooler, has never been wet before. The KUUL evaporative media will emit an odor the first time you wet it that lasts approximately one to three weeks. Keep your evaporative cooler in an open area until the odor goes away or put a capful of laundry softener directly in the tank. After approximately two weeks of operation, the odor should disappear.

## **Q. My Portacool portable evaporative cooler isn't putting out cool air.**

A. First, make sure the water source and electricity source are connected and working. Second, check to see if the KUUL evaporative media is damp. If not, adjust the water flow with the water adjustment valve. Third, make sure there is water in the tank. It should be allowed to fill before you turn the pump on.

## **Q. What is the best environment to product the most cool air from my Portacool portable evaporative cooler?**

A. For optimum performance, the temperature should be 85° F or higher and the relative humidity should be below 75%. However, Portacool portable evaporative coolers will reduce the temperature in almost any environment, making it more pleasant.

## **Q. How often does the KUUL evaporative media need to be replaced in my evaporative cooler?**

A. Depending on the quality of maintenance, water quality and frequency of use, KUUL evaporative media typically lasts up to five years.

## **Q. What is the difference between evaporative cooler and misting systems?**

A. Misting systems spray a shower of water into the air that collects on people, objects, equipment, floors, etc. Portacool portable evaporative coolers use the process of evaporation to produce cooler air, but do not discharge a mist.

## **Q. Where can I buy replacement parts and accessories for my Portacool portable evaporative cooler?**

A. Replacement parts may be purchased directly from Portacool Parts/Technical Support department or [www.portacoolparts.com](http://www.portacoolparts.com). You may also buy replacement parts from any Portacool distributor.

# FAQ

**Q. What amount of moisture is added to the air by my evaporative cooler?**

A. An increase in humidity of approximately two to five percent is produced, depending on the temperature and humidity of the environment. This increase is not noticeable in a ventilated area where the air produced by the cooler is exhausted.

**Q. How long will the water supply last in my evaporative cooler's tank?**

A. With no direct water source available, the water will evaporate in a filled tank within two to 10 hours of operation, depending on the water capacity of the evaporative cooler, ambient conditions, temperature and humidity. A water source for refilling the tank is recommended by the manufacturer.

**Q. Where are the model and serial numbers found?**

A. The model number can be found on a metal plate on the outside of the cooler. Model numbers begin with the letters "PAC." Serial numbers are all-digits.

**Q. What if my question is not answered here?**

A. Our U.S.-based Tech Support staff is available 8 a.m. to 5 p.m. Central Time, Monday through Friday at 1-888-COOL-AID or you can e-mail them at [support@portacool.com](mailto:support@portacool.com).

# FAQ

## HOW TO REPLACE YOUR KUUL® EVAPORATIVE MEDIA

### Step 1

Be sure to unplug your Portacool portable evaporative cooler before doing any maintenance. Lock the casters to keep your evaporative cooler from moving while you are working. Remove the flap and KUUL evaporative media from the evaporative cooler. The flap is attached at the top of the evaporative cooler with three screws. Remove the three screws and set the flap aside.

### Step 2

All KUUL evaporative media must be removed before accessing the inside of the evaporative cooler. Remove the center set of KUUL evaporative media first by grasping at the top and tilting it out and away from the evaporative cooler. While tilting the KUUL evaporative media out, lift it up and out of the evaporative cooler.

### Step 3

Remove remaining KUUL evaporative media in the same manner. Set aside in a safe place to prevent damage while out of the evaporative cooler. Once all the KUUL evaporative media has been removed, you should have access to the inside of the evaporative cooler and internal components.

# KEY PARTS

## 370

<b>MOTOR</b>	PARMTRH3700A	<b>FAN ASSEMBLY</b>	PARFANH370F0
<b>PUMP</b>	PARPMPH3700A	<b>HMI</b>	PARCTLH37000
<b>MEDIA</b>	PARKULH37000	<b>COVER</b>	PARCVRH37000
<b>CASTERS (4)</b>	PARCSTH370F0	<b>MEDIA FLAP</b>	PARFLPH37000
		<b>VFD</b>	PARCTLV37000

Additional parts can be found at [www.portacoolparts.com](http://www.portacoolparts.com)

# REGISTER

Please complete this form and mail in a stamped envelope to:  
Portacool, 711 FM 2468, Center, TX 75935 or register online at:  
[www.portacool.com/support](http://www.portacool.com/support)

**DATE OF PURCHASE**

**MODEL NUMBER**

**SERIAL NUMBER**

**YOUR NAME**

**ADDRESS**

**CITY**  **STATE**  **ZIP CODE**

**PHONE NUMBER**  ( ) -  **EMAIL**  @

**WHO DID YOU PURCHASE FROM?**

## PRIMARY USE:

- Auto/Aviation  Farm/Pet  Industrial  
 Hospitality  Home  Other

## PRIMARY REASON FOR PURCHASE:

- Safety  Sustainability  
 Productivity  Total cost of ownership

## DESCRIBE YOUR PURCHASE:

- Purchased before  First time buyer  
 Purchased other brand

**REGISTER YOUR PRODUCT AT [WWW.PORTACOOOL.COM](http://WWW.PORTACOOOL.COM)**









# PORTACOOOL™

WHEN COMFORT COUNTS™

## **CUSTOMER SERVICE CONTACT**

**1-936-598-5651 ★ 1-800-695-2942**

**ORDERS@PORTACOOOL.COM**

## **TECHNICAL/PARTS CONTACT**

**1-936-598-5651 ★ 1-800-695-2942**

**SUPPORT@PORTACOOOL.COM**

**VISIT PORTACOOOL.COM**

**OR CALL 1-936-598-5651**

**FOR MORE INFORMATION**

Portacool, LLC • Manufacturer of Portacool™

portable evaporative coolers and

KUUL® evaporative media

711 FM 2468 • Center, Texas 75935 • 936-598-5651

www.portacool.com • www.theKUULeffect.com

The manual is available in other languages.

To download a digital copy, please visit  
[www.portacool.com](http://www.portacool.com).

El manual está disponible en otros idiomas.

Para descargar una copia digital, por favor  
visite [www.portacool.com](http://www.portacool.com).

Le manuel est disponible en d'autres langues.

Pour télécharger une copie numérique, se il  
vous plaît visitez [www.portacool.com](http://www.portacool.com).

والدليل هو متاح في اللغات الأخرى. لتحميل  
نسخة رقمية، يرجى زيارة [www.portacool.com](http://www.portacool.com)

**MANR0002**

**REGISTER YOUR PRODUCT AT [WWW.PORTACOOOL.COM](http://WWW.PORTACOOOL.COM)**